

Enclosures can be Factory Modified (Milling, Drilling, Printing etc.)
 Contact Factory (modshop@hammfg.com) for quotes
 Solid models of this enclosure available in .stp or .x_t
 (Part number and text placement/orientation on our products are subject to change,
 we do not recommend using them as a locating reference for modification purposes)

NOTE	
Purchased assembly includes base, cover, end panels, extrusions, cover screws, panel screws and rubber feet.	
Recommended Cover screw torque -- 14-15 lbf-in (160-170 cN-m)	
1402	
1402K Regular Enclosure	
BASE: 12 ga. Aluminum (beige) (Pkg 2)	
PANEL: 14 ga. Aluminum (natural) (Pkg 2)	
Extrusion: Aluminum (natural) (Pkg 2)	
Cover screws: (#10-32 X 1/4" self tap) (Pkg 8)	
Panel screws: (#4-24 X 1/4" self tap) (Pkg 18)	
Self Adhesive Rubber feet (Pkg 4)	

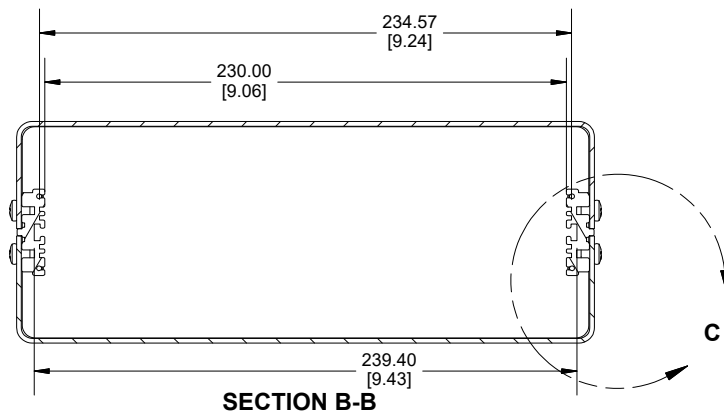

DETAIL C
SCALE 1.3

Dimensions:
mm
[inches]

**HAMMOND
MANUFACTURING.**

1402K

www.hammondmfg.com