

EXTRUSION

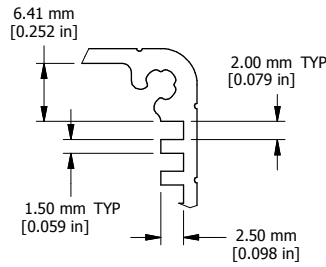

DETAIL A

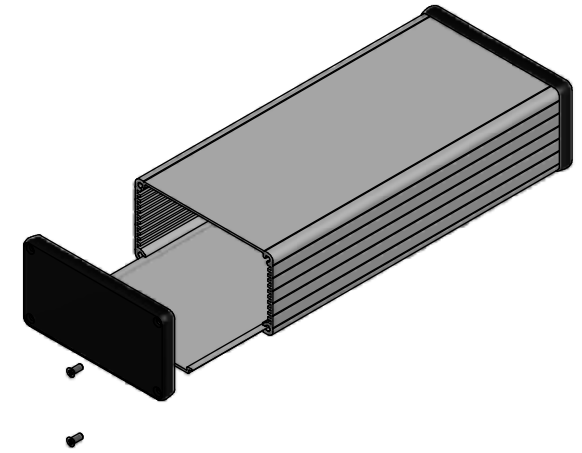

EXPLODED ASSEMBLY VIEW

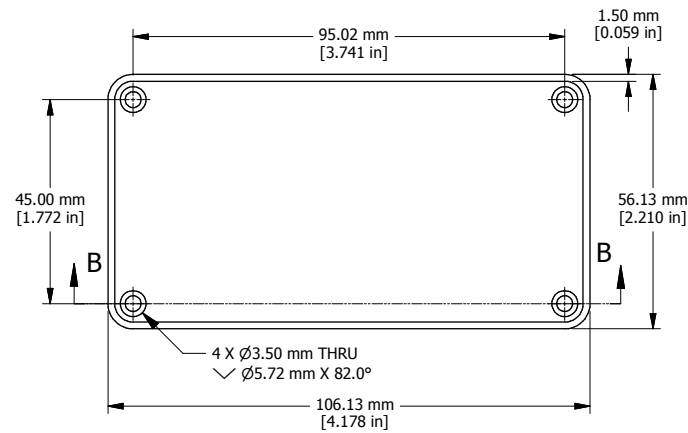
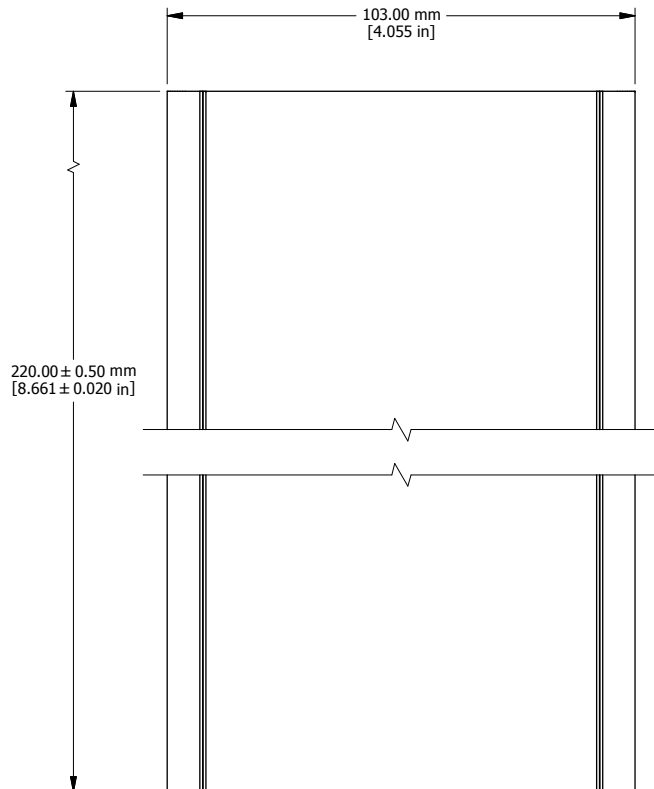

CLOSED BEZEL

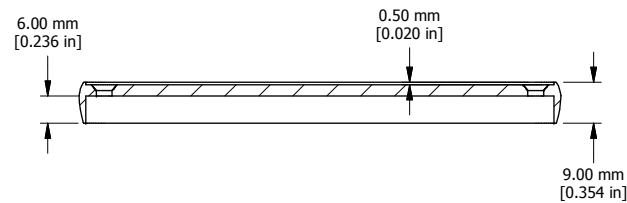

Enclosures can be Factory Modified (Milling, Drilling, Printing etc.)
 Solid models of this enclosure available in STEP or IGES.
 Contact Factory mjm@hammondmfg.com

NOTE

Purchased assembly includes box, plastic bezels, #6 Taptight screws and self adhesive rubber feet.

Box made from Extruded Aluminum 6063.

Bezels made with ABS.

1455N2202

PART NUMBERS

Clear Anodized	1455N2202
Black Anodized	1455N2202BK

ACCESSORIES

See website for accessories.



**HAMMOND
 MANUFACTURING™**

1455N2202

www.hammondmfg.com