

TOP VIEW

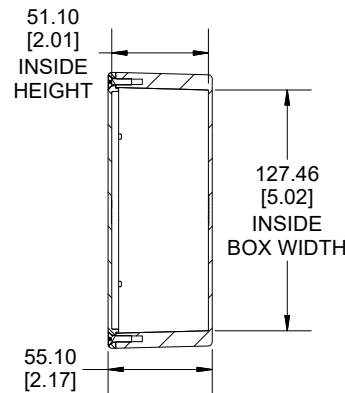

**SECTION A-A
END VIEW**

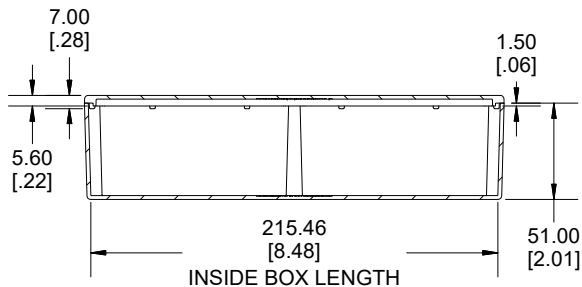
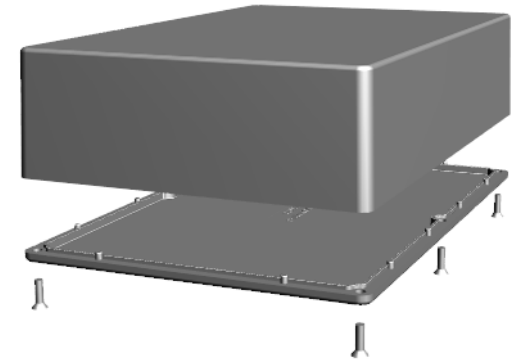

**SECTION B-B
SIDE VIEW**

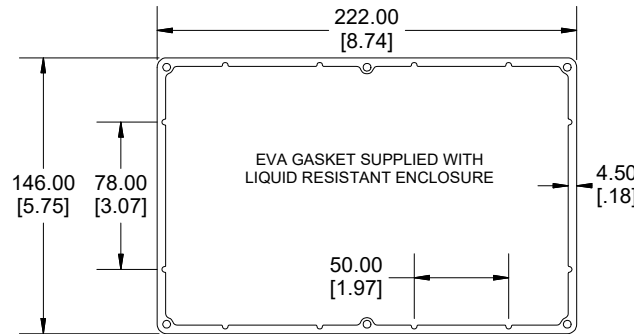

EVA GASKET SUPPLIED WITH LIQUID RESISTANT ENCLOSURE

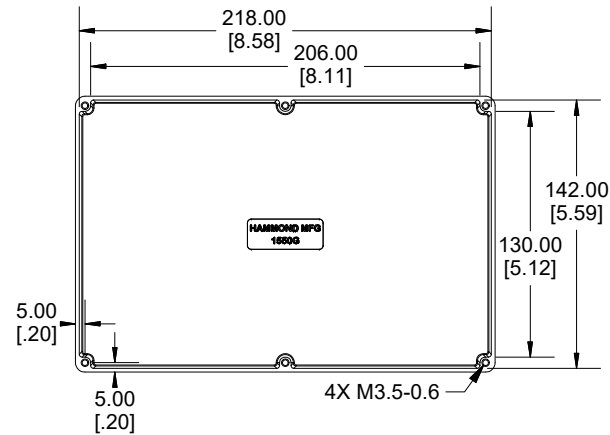

INSIDE BOX

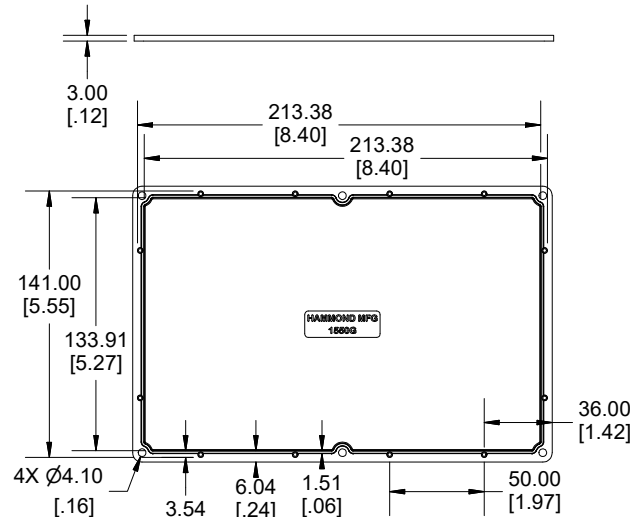

INSIDE LID

Enclosures can be Factory Modified (Milling, Drilling, Printing etc.)
Contact Factory (modshop@hammfg.com) for quotes
Solid models of this enclosure available in .stp or .x_t
(Part number and text placement/orientation on our products are subject to change,
we do not recommend using them as a locating reference for modification purposes)

NOTE

Purchased assembly includes box, lid and 6 cover screws.
Box and lid are made from Diecast Aluminum Alloy.
EVA Gasket supplied with liquid resistant enclosure.

PART NUMBERS

1550G Enclosure	
Natural Finish Enclosure	1550G
Black Textured Enclosure	1550GBK
1550G Liquid Resistant Enclosure (EVA Gasket)	
Natural Finish Enclosure	1550WG
Black Textured Enclosure	1550WGBK
ACCESSORIES	
Recommended Torque: 75 ozf.in / 55 cN.m	
Standard Cover Screws	
Plated Cover Screws (Pkg 100) [M3.5-0.6 x 12mm]	1550MS100
Black Cover Screws (Pkg 100) [M3.5-0.6 x 12mm]	1550MS100BK
EVA Pre-formed Gasket Black	1550GEGASKET
Silicone Pre-formed Gasket Black	1550GSGASKET

Dimensions:
mm
[inches]

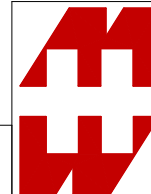

**HAMMOND
MANUFACTURING®**

1550G

www.hammondmfg.com