

Enclosures can be Factory Modified ( Milling, Drilling, Printing etc.)  
Contact Factory [mjm@hammondmfg.com](mailto:mjm@hammondmfg.com) for quotes  
Solid models of this enclosure available in STEP or IGES.  
(Part number and text placement/orientation on our products are subject to change, we do not recommend using them as a locating reference for modification purposes)

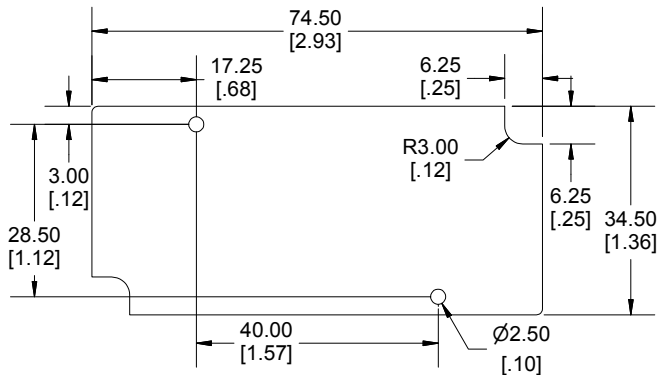
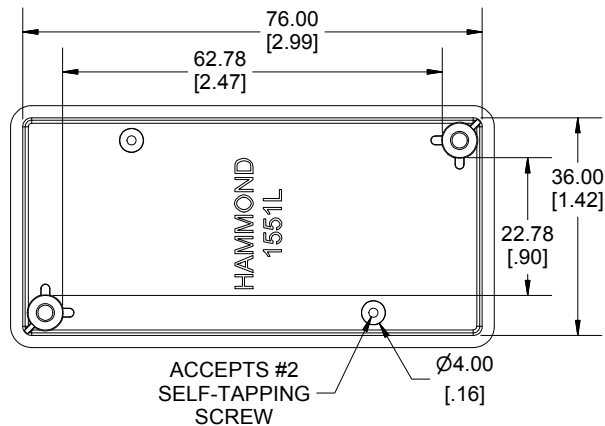

Dimensions:  
mm  
[inches]

**NOTE**

Purchased assembly includes box, lid, 2 cover screws.  
Enclosure molded from general purpose ABS Plastic.  
Other materials / colours available consult factory.

**Recommended Torque : (35-43) Ozf.in / (25-30) cN.m**

**PART NUMBERS**

1551LFL Enclosure		
Black Enclosure - Ral 9011 - UL94 - HB		1551LFLBK
Gray Enclosure - RAL 7035 - UL94 - HB		1551LFLGY
Tranlucent Blue - UL94 - HB		1551LFLTBU
ACCESSORIES		
Black Cover Screws #4 X 1/2" Self-tapping		1591TS100BK (Pkg 100)
Plated Cover Screws #4 X 1/2" Self-tapping		1591TS100 (Pkg 100)
P.C. Board Screws [#2 x 3/16" self-tapping (4.8mm)]		1551ATS100 (Pkg 100)

**HAMMOND MANUFACTURING**

**1551LFL**

[www.hammondmfg.com](http://www.hammondmfg.com)