

Enclosures can be Factory Modified ( Milling, Drilling, Printing etc.)  
 Contact Factory [mjm@hammondmfg.com](mailto:mjm@hammondmfg.com) for quotes  
 Solid models of this enclosure available in STEP or IGES.  
 (Part number and text placement/orientation on our products are subject to change,  
 we do not recommend using them as a locating reference for modification purposes)

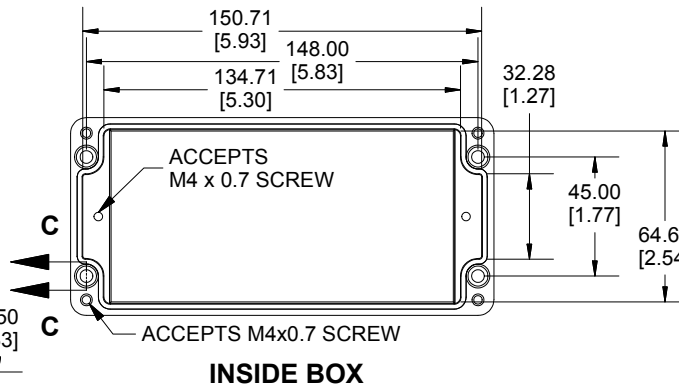
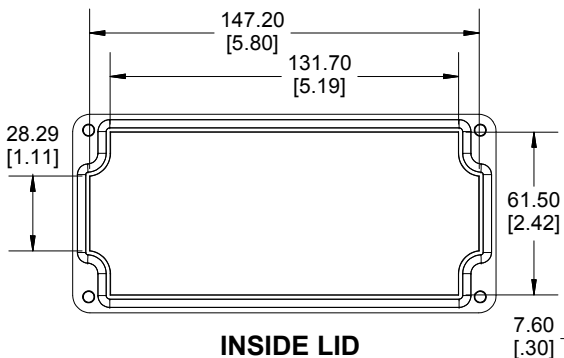

NOTE	
Purchased assembly includes Box, Lid, Gasket and 4 cover screws	
Enclosure Molded from Glass Reinforced Polyester	
<b>Recommended cover screw torque 6-7.5 lbf.in (70-85 cN.m)</b>	
PART NUMBERS	
1590ZGRP083 Enclosure	
Grey Enclosure	1590ZGRP083
ACCESSORIES	
Copper Ground Hardware (50 Pack) [M4 - 0.7 X 6mm / M4 Washer]	SCGM4-50
Stainless Steel Cover Screw (50 Pack) [M4 - 0.7 x 25mm]	SC583-50
Steel Inner Panel	1590ZGRP083PL
Hinge Kit (2 Pack)	1427HK

Dimensions:  
mm  
[inches]

**HAMMOND  
MANUFACTURING**

**1590ZGRP083**

[www.hammondmfg.com](http://www.hammondmfg.com)