

**TOP VIEW**

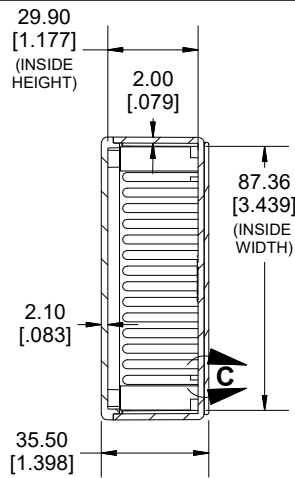

**SECTION A-A**

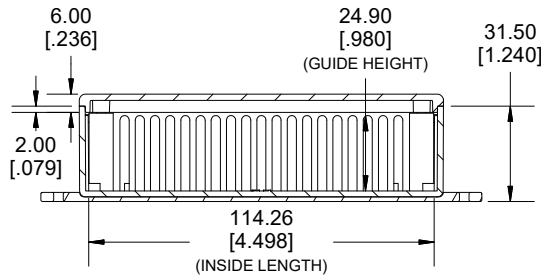
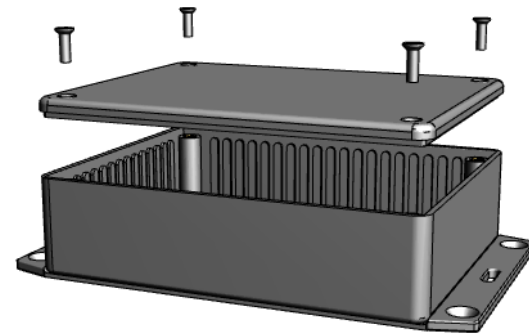

**SECTION B-B  
SIDE VIEW**

**DETAIL C**

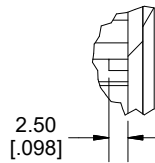

**DETAIL D**

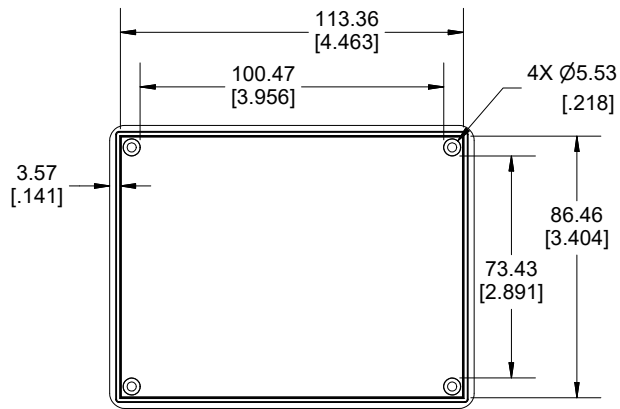
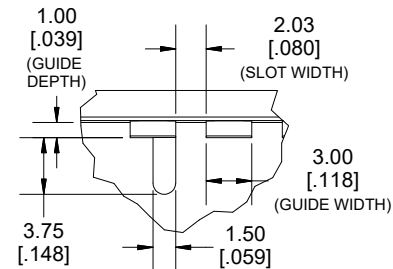

**INSIDE LID**

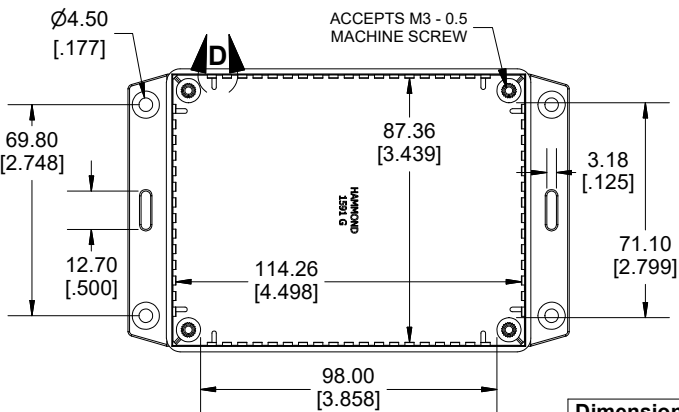

**INSIDE BOX**

Enclosures can be Factory Modified (Milling, Drilling, Printing etc.)  
 Contact Factory (modshop@hammfg.com) for quotes  
 Solid models of this enclosure available in .stp or .x\_t  
 (Part number and text placement/orientation on our products are subject to change,  
 we do not recommend using them as a locating reference for modification purposes)

**NOTE**

Purchased assembly includes box, lid, 4 cover screws, and pre-installed brass inserts.  
 Enclosure made from FRABS

**Recommended Torque: 42-57 ozf.in (30-40 cN.m)**

**PART NUMBERS**

**1591G Enclosure**

Flame Retardant ABS Black	1591GF2BK
Flame Retardant ABS Grey	1591GF2GY

**Accessories**

Plated Cover screw	1591MS100 (Silver)
M3 - 0.5 X 10mm (100Pkg)	1591MS100BK (Black)
PC Board Card Adapters	1591Z6 (6Pkg)
	1591Z50 (50 Pkg)
Nylon Belt / Pocket clip	1591Z100 (100Pkg)
	1599CLIP (Black)
	1599CLIPGY (Grey)
Clear Lids - Flame Retardant	1591GC
Polycarbonate - Lid ONLY	

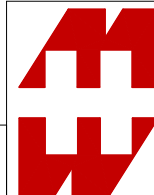

**HAMMOND  
MANUFACTURING.**  
**1591GF2**

Dimensions:  
mm  
[inches]

www.hammondmfg.com

REV: 07.01.2020