

TOP VIEW

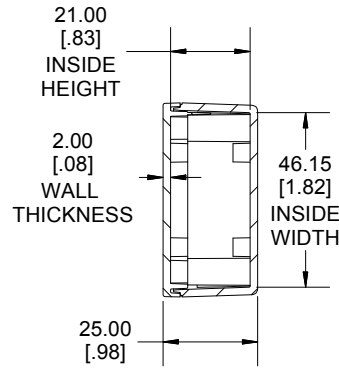

**SECTION B-B
END VIEW**

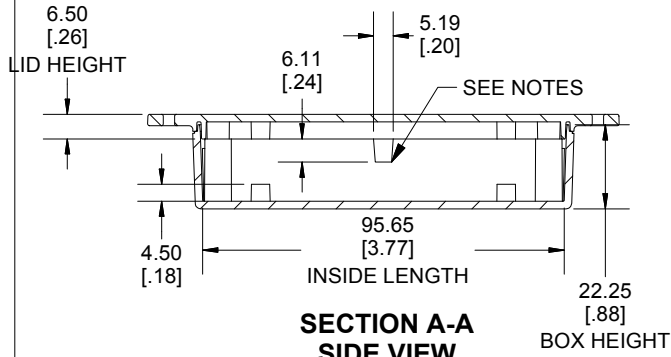

**SECTION A-A
SIDE VIEW**

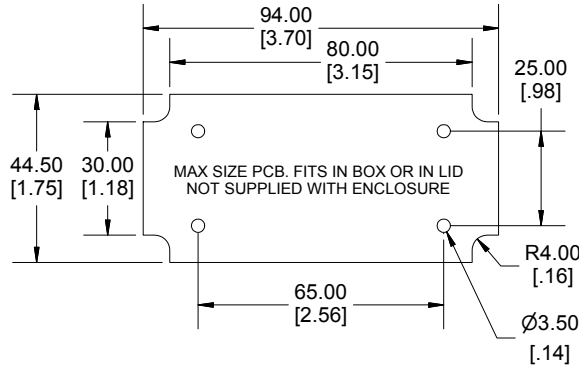

MAX SIZE PCB. FITS IN BOX OR IN LID
NOT SUPPLIED WITH ENCLOSURE

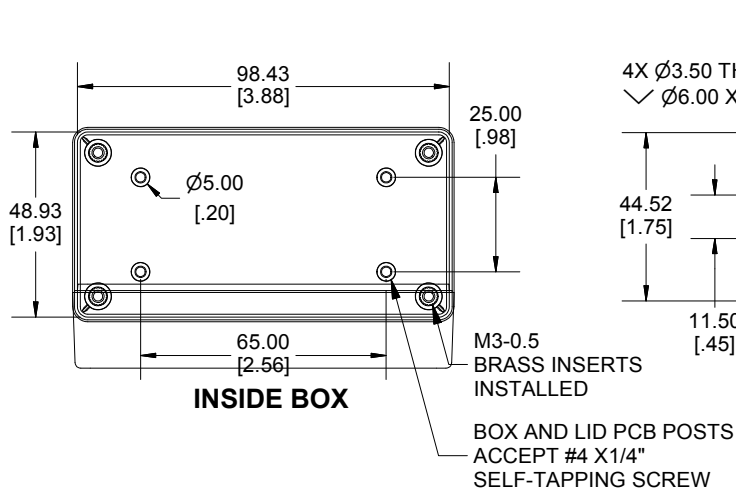

INSIDE BOX

BOX AND LID PCB POSTS
ACCEPT #4 X1/4"
SELF-TAPPING SCREW

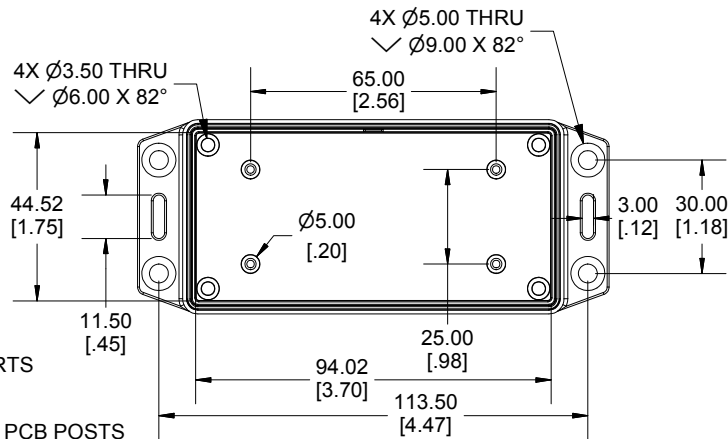

INSIDE LID

Dimensions:
mm
[inches]

Enclosures can be Factory Modified (Milling, Drilling, Printing etc.)
Contact Factory mjm@hammondmfg.com for quotes
Solid models of this enclosure available in STEP or IGES.
(Part number and text placement/orientation on our products are subject to change,
we do not recommend using them as a locating reference for modification purposes)

| NOTE | |
|--|--|
| Tab dimensions show maximum size, tab may vary. | |
| Purchased assembly includes box, lid, 4 cover screws and installed brass inserts. Enclosure molded from FRABS UL 94-V0 Plastic. | |
| Other materials / colours available consult factory. | |
| Recommended Torque : (43-50) Ozf.in / (30-35) cN.m | |

| PART NUMBERS | |
|-------------------------------------|-----------------------|
| 1591XXAFL Enclosure | |
| Black Textured Enclosure | 1591XXAFLBK |
| Gray Textured Enclosure | 1591XXAFLGY |
| Translucent Blue Textured Enclosure | 1591XXAFLTBU |
| ACCESSORIES | |
| Black Cover Screws [M3-0.5 X 10mm] | 1591MS100BK (Pkg 100) |
| Plated Cover Screws [M3-0.5 X 10mm] | 1591MS100 (Pkg 100) |
| P.C. Board Screws | 1593ATS50 (Pkg 50) |
| #4 x 1/4" self-tapping (6.4mm)] | 1593ATS100 (Pkg 100) |

**HAMMOND
MANUFACTURING®**

1591XXAFL

www.hammondmfg.com