

TOP VIEW

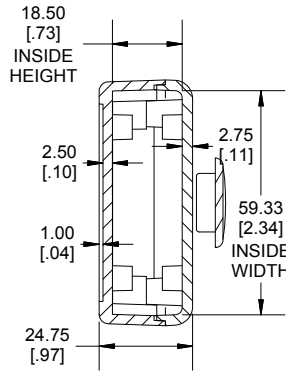

END VIEW SECTION A-A

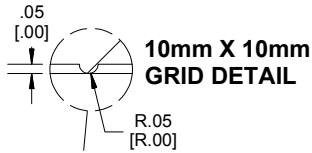
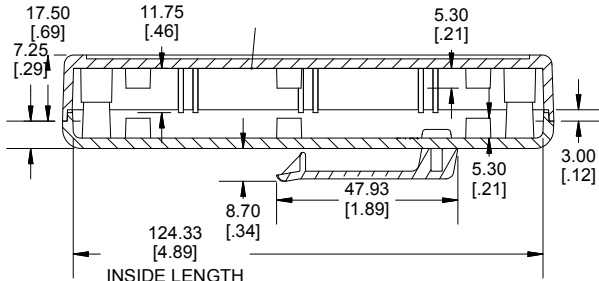
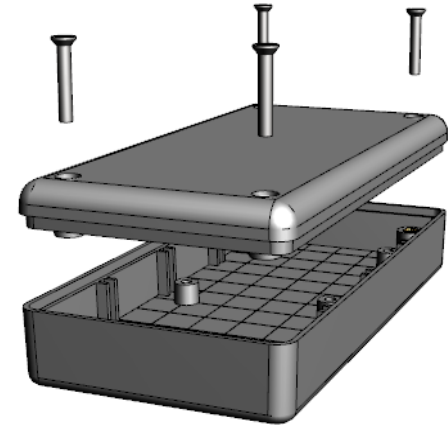

SIDE VIEW SECTION B-B

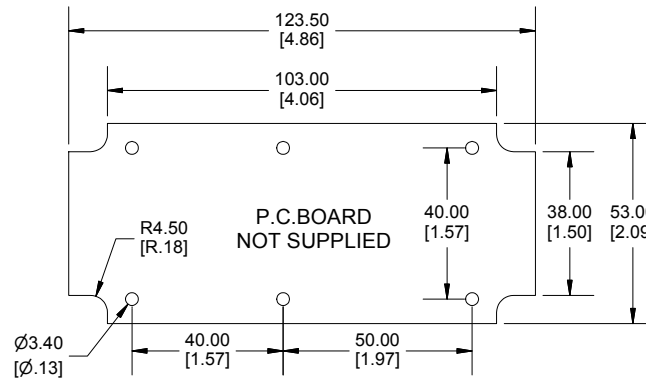

MAXIMUM P.C. BOARD

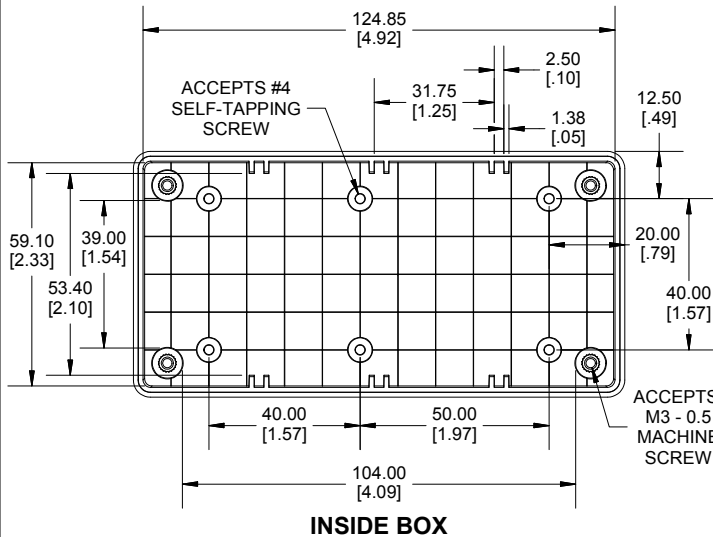

INSIDE BOX

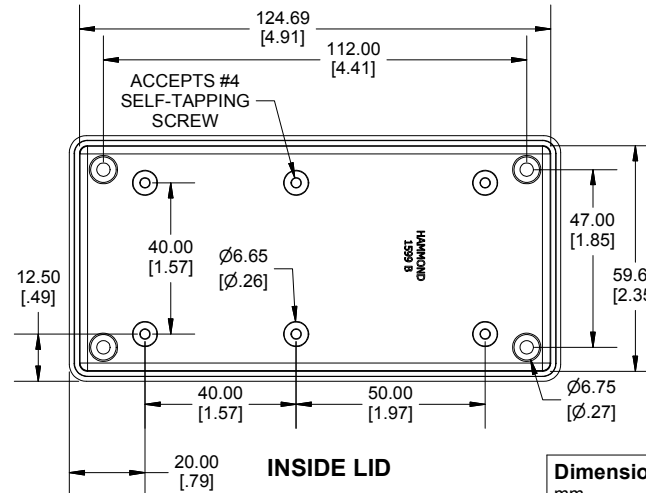

INSIDE LID

Enclosures can be Factory Modified (Milling, Drilling, Printing etc.)
 Contact Factory mjm@hammondmfg.com for quotes
 Solid models of this enclosure available in STEP or IGES.
 (Part number and text placement/orientation on our products are subject to change, we do not recommend using them as a locating reference for modification purposes)

NOTE

Purchased assembly includes box, lid, belt clip, 2 belt clip screws and 4 cover screws.
 Box and Lid are made from Flame retardant ABS with a UL flammability rating of 94 V-0

Recommended Torque: 42-57 oz.in (30-40 cN.m)

PART NUMBERS

1599B Fire Retardant ABS

Black FR-ABS	1599BBKCP
Grey FR-ABS	1599BGYCP

ACCESSORIES

Cover Screws (Pkg 100)	1594MS100 (Grey)
[M3 - 0.5 x 18mm Machine Screws]	1594MS100BK (Black)
P.C Board Screws (Pkg of 50 or 100)	1593ATS50
[#4 x 1/4" Pan Head Self Tapping Screws]	1593ATS100
Nylon Belt Clip	1599CLIP (Black)
	1599CLIPGY (Grey)
ABS Divider Panel Grey	1599BD

Dimensions:
mm
[inches]

HAMMOND MANUFACTURING
1599BCP
www.hammondmfg.com