

Enclosures can be Factory Modified (Milling, Drilling, Printing etc.)
Contact Factory mjm@hammondmfg.com for quotes
Solid models of this enclosure available in STEP or IGES.
(Part number and text placement/orientation on our products are subject to change.
We do not recommend using them as a locating reference for modification purposes)

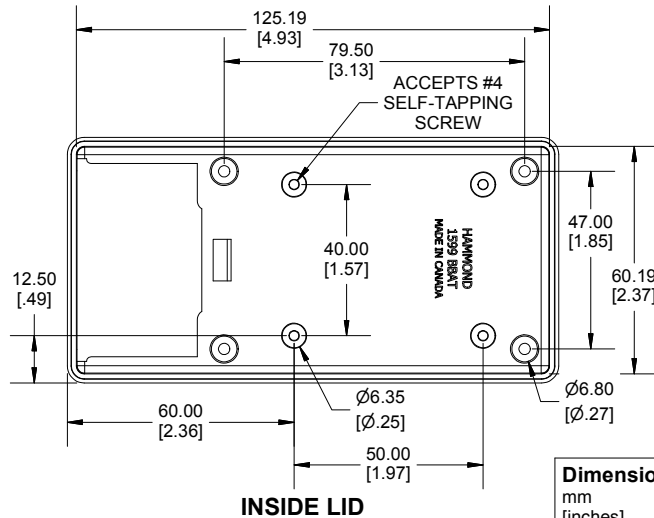
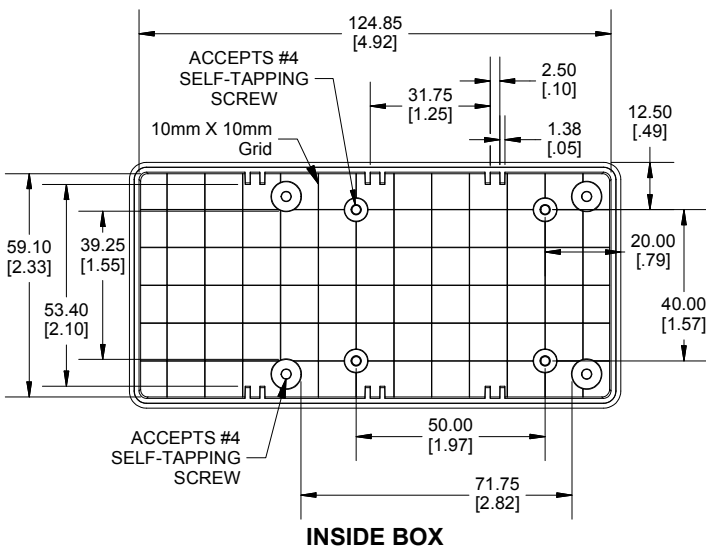

Dimensions:
mm
[inches]

NOTE

Purchased assembly includes box, lid, battery door and 4 cover screws.
Box and Lid are made from General Purpose ABS

Recommended Torque: 42-57 ozf.in (30-40 cN.m)

PART NUMBERS

1599BSBAT General Purpose ABS

Grey GP-ABS	1599BSGYBAT
-------------	-------------

ACCESSORIES

Cover Screws (Pkg 100) [#4 x 3/4" Self Tapping Screw]	1599BTS100
P.C Board Screws (Pkg of 50 or 100) [#4 x 1/4" Pan Head Self Tapping Screws]	1593ATS50 1593ATS100
Nylon Belt Clip	1599CLIP (Black) 1599CLIPGY (Grey)
ABS Divider Panel Grey	1599BD

HAMMOND MANUFACTURING

1599BSBAT

www.hammondmfg.com