

1 2 3 4 5 6

A

B

C

D

A

B

C

D

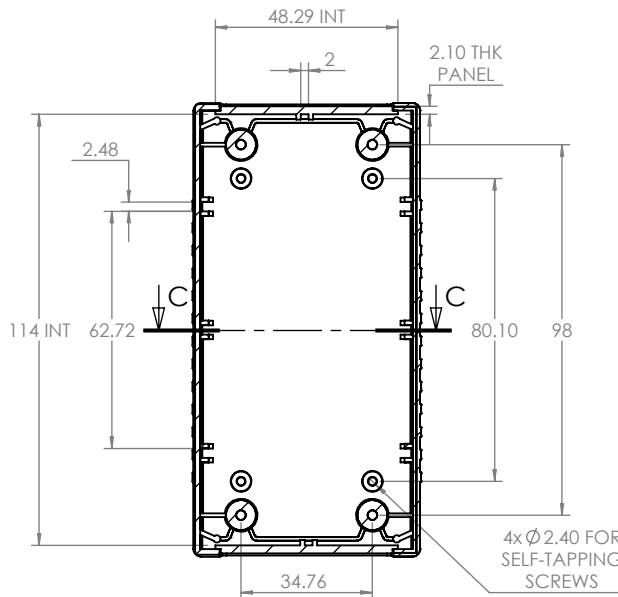

SECTION B-B

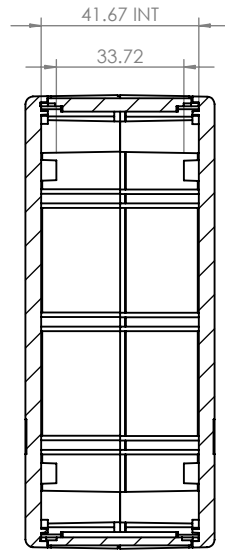
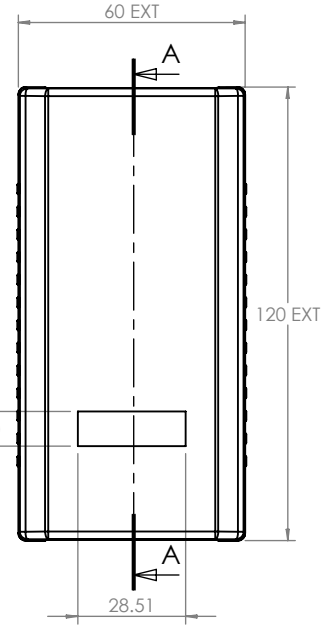
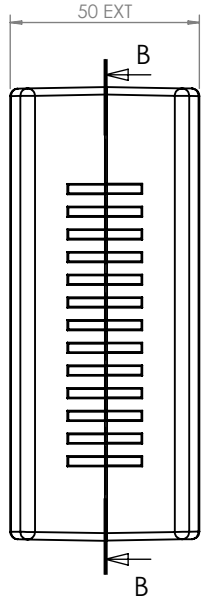

SECTION A-A

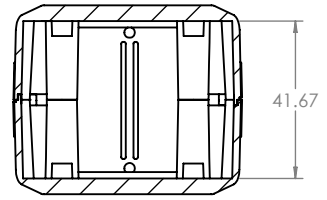

SECTION C-C

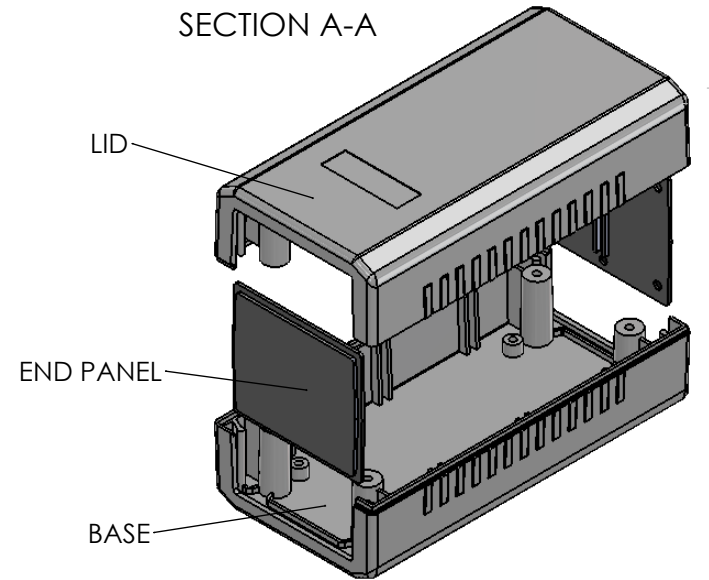
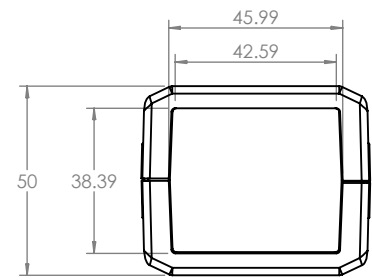

 CAMDENBOSS JAMES CARTER RD, MILDENHALL, SUFFOLK. IP28 7DE TEL: 01638 716101 FAX: 01638 716554 EMAIL: Sales@CamdenBoss.com WEB: www.CamdenBoss.com		UNLESS OTHERWISE SPECIFIED: DIMENSIONS ARE IN MILLIMETERS		DO NOT SCALE DRAWING		REVISION. 0	
		GENERAL TOLERANCES +/- 0.2		TITLE: GENERAL ASSY DRAWING FOR 3400 SERIES			
DRAWN		NAME	SIGNED	DATE	MATERIAL.		DWG NO.
CHKD		JAMIE JACOBS	JNJ	09/11/12	UL94-VO		3400-12
					PROJECTION.		SCALE: 1 : 2
							SHEET 1 OF 1

1 2 3 4 5 6

A4