

OVERALL ASSEMBLY DIMENSIONS:

EXTERNAL - 99 x 57 x 33.9

INTERNAL - 76 x 51 x 28.70

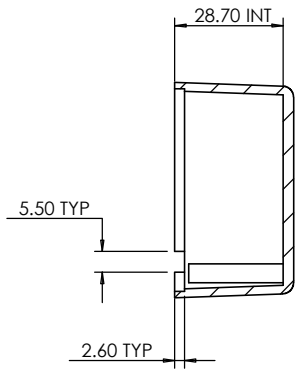

SECTION C-C

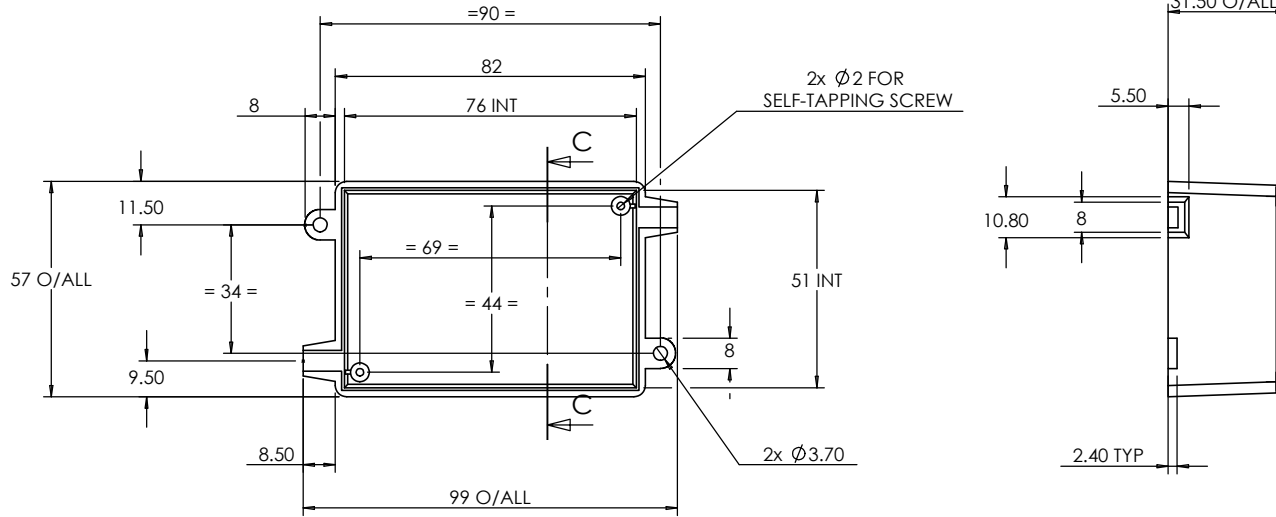

BASE

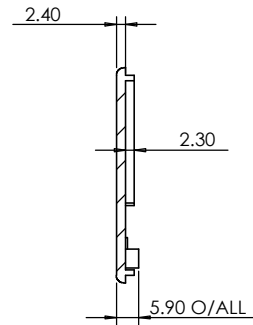
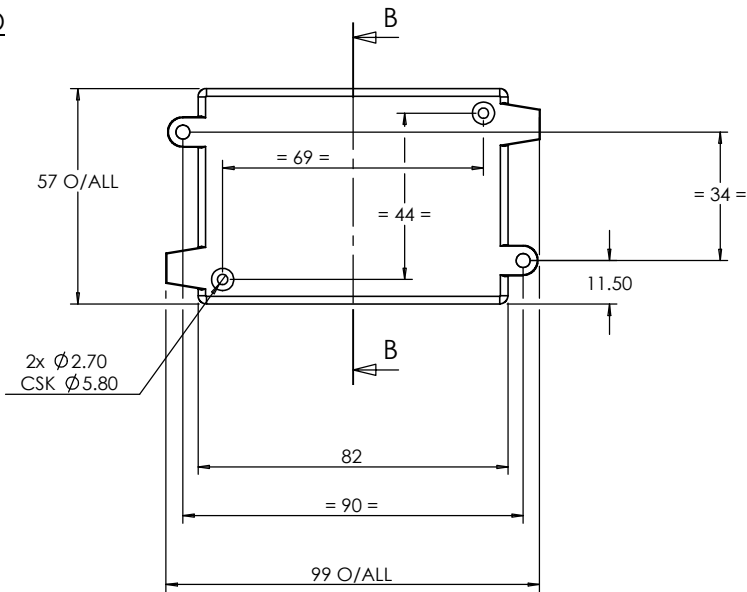

LID

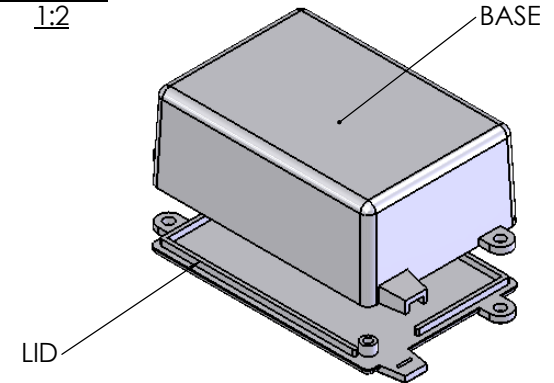

SECTION B-B

ISO VIEW  
1:2



 <b>CAMDENBOSS</b> JAMES CARTER RD, MILDENHALL, SUFFOLK, IP28 7DE TEL: 01638 716101 FAX: 01638 716554 EMAIL: Sales@CamdenBoss.com WEB: www.CamdenBoss.com		UNLESS OTHERWISE SPECIFIED: DIMENSIONS ARE IN MILLIMETERS		DO NOT SCALE DRAWING		REVISION. 0	
		FINISH: <b>FINE SPARK</b>		TITLE: <b>ASSEMBLY DRG FOR 400-019</b>			
DRAWN SUBKHANKULOVA		SIGNED LS		DATE 05/06/09		MATERIAL: <b>ABS</b>	
CHKD STUART HARDINGE		SIGNED SJH		DATE 05/06/09		DWG NO. <b>400-019</b>	
PROJECTION. 				SCALE: 1:2		SHEET 1 OF 1	
						A4	