

OVERALL ASSEMBLY DIMENSIONS:

EXTERNAL - 115 x 65 x 30.2

INTERNAL - 109 x 59 x 24.8

(1) 4x M4 UNIT ASSEMBLY SCREW

(2) 2x SELF-TAPPING INTERNAL MOUNTING SCREW

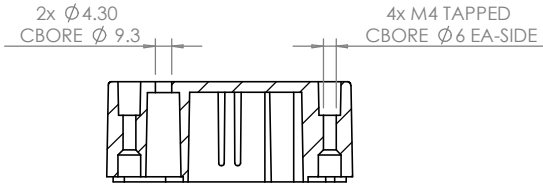

SECTION B-B

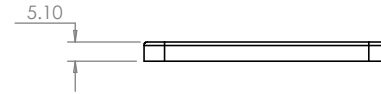

SCREW (1)  
O-RING  
SCREW (2)  
SPRING WASHER

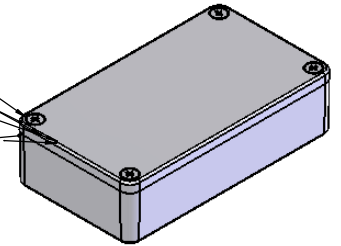

ISO VIEW  
1:3

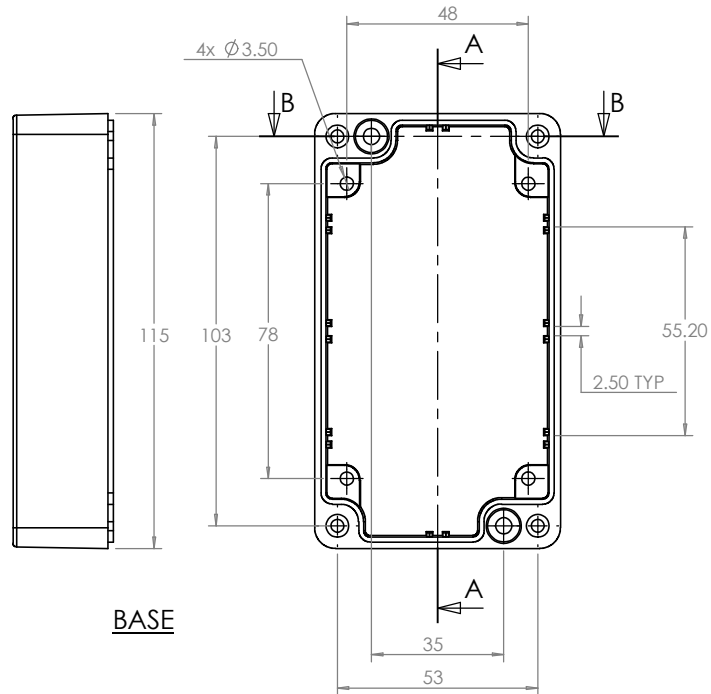

BASE

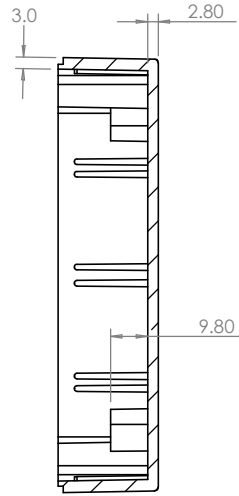

SECTION A-A

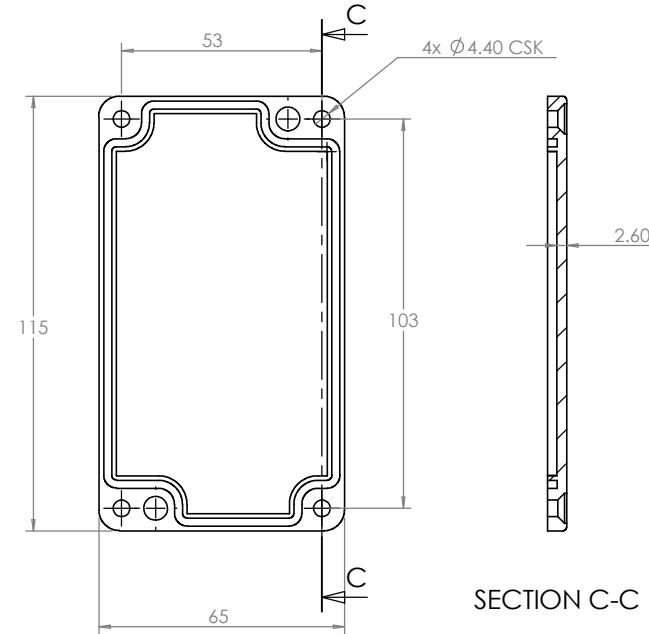

SECTION C-C

LID

 <b>CAMDENBOSS</b> JAMES CARTER RD, MILDENHALL, SUFFOLK, IP28 7DE TEL: 01638 716101 FAX: 01638 716554 EMAIL: Sales@CamdenBoss.com WEB: www.CamdenBoss.com				UNLESS OTHERWISE SPECIFIED: DIMENSIONS ARE IN MILLIMETERS		DO NOT SCALE DRAWING		REVISION. O		
				FINISH. <b>SMOOTH</b>		TITLE: <b>ASSEMBLY DRG FOR 5500-06</b>				
DRAWN S.HARDINGE		SIGNED SJH		DATE 04/01/06		MATERIAL. DIE-CAST ALUMINIUM		DWG NO. <b>5500-06</b>		A4
CHK'D -		-		-		PROJECTION.		SCALE: 1:2		SHEET 1 OF 1