

# 5500 Series Waterproof Diecast Enclosure

## Product overview

Heavy duty aluminium diecast boxes for industrial, control and mechanical engineering applications. Ideal for extreme conditions.

- Aluminium alloy
- Tongue and groove construction
- Lid incorporates a recessed gasket seal
- PCB pillars in base
- Low draft angle provides for maximum internal volume
- 5500 series has been designed to meet the requirements of IP65 (with supplied neoprene gasket)



SPECIFICATION	
Materials	Aluminium alloy ADC-12 (Al - Si - Cu based alloy)
Protection class	5500 series has been designed to meet the requirements of IP65 (neoprene gasket provided for IP65 seal)
Standard colours	Natural as standard Hammerstone or powder coating optional
Standard unit includes	Case, lid, neoprene gasket, 4x fixing screws

NATURAL RAL	LENGTH	WIDTH	HEIGHT
5500-04	64mm	58mm	35mm
5500-02	90mm	36mm	30mm
5500-06	115mm	65mm	30mm
5500-11	115mm	65mm	55mm
5500-13	115.25mm	90.5mm	55.7mm
5500-37	121mm	121mm	101mm
5500-15	148mm	108mm	75mm
5500-39	159mm	109mm	102mm
5500-20	171mm	121mm	55mm
5500-24	222mm	146mm	55mm
5500-25	222mm	146mm	82mm

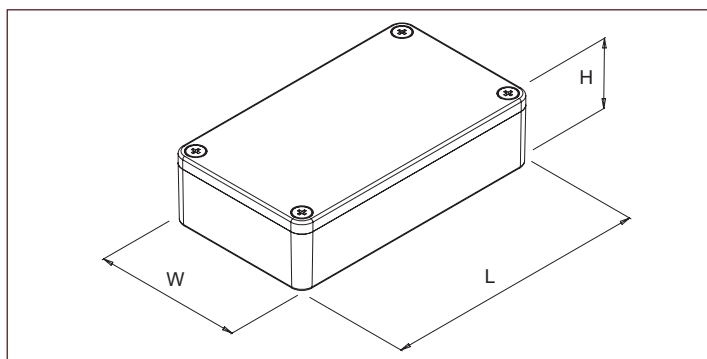

## KEY FEATURES

Alumunium alloy | Neoprene gasket for IP65 seal | PCB pillars

