

SECTION C-C

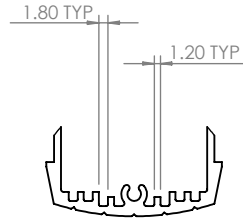

DETAIL A

SECTION D-D

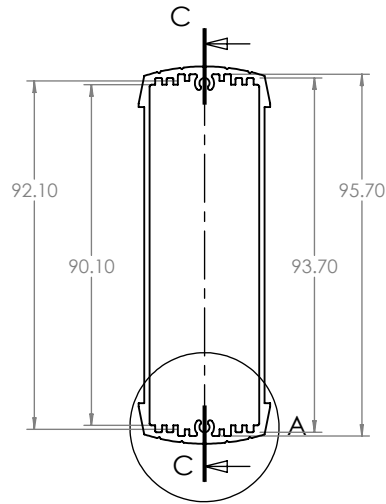
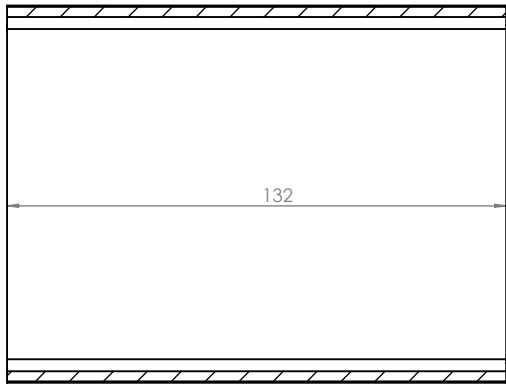
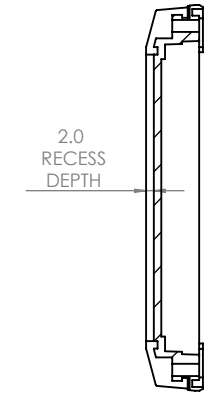

END COVER

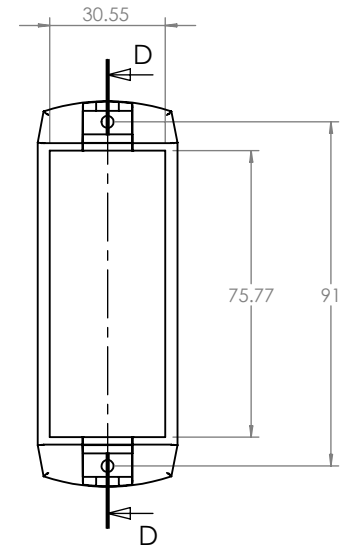

PROFILE

ASSEMBLY

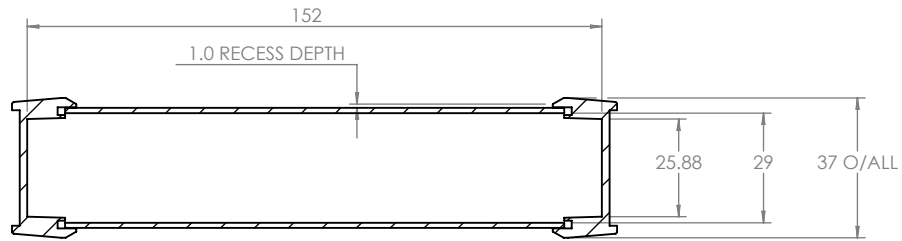

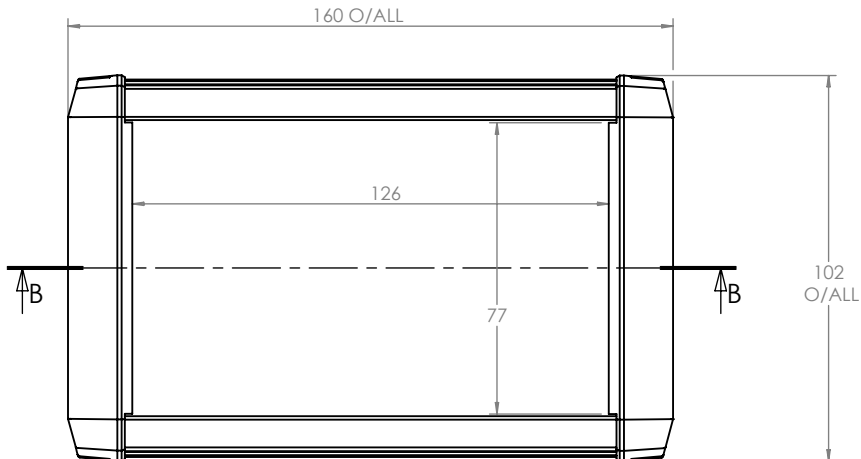

SECTION B-B

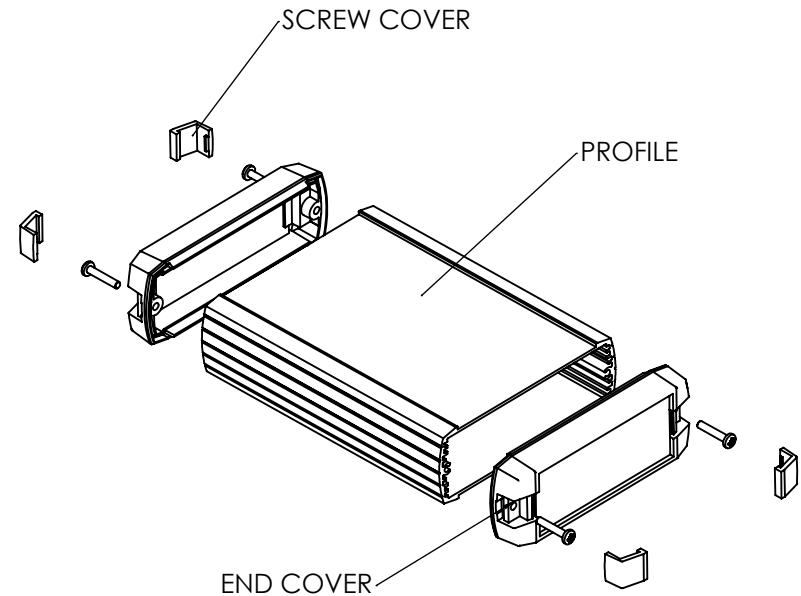

ISO VIEW
1:3



 CAMDENBOSS JAMES CARTER RD, MILDENHALL, SUFFOLK. IP28 7DE TEL: 01638 716101 FAX: 01638 716554 EMAIL: Sales@CamdenBoss.com WEB: www.CamdenBoss.com		UNLESS OTHERWISE SPECIFIED: DIMENSIONS ARE IN MILLIMETERS		DO NOT SCALE DRAWING	REVISION. 0
		FINISH: EPOXY PAINT		TITLE: GNL ASSEMBLY DRG FOR 55 SERIES	
DRAWN	NAME IAN PAGANO	SIGNED I.P.	DATE 06/08/13	MATERIAL: ALUMINIUM	DWG NO. CEAREPB03
CHKD	-	-	-	PROJECTION. 	SCALE: 1 : 2
					SHEET 1 OF 1