

4.01 PILLAR HEIGHT  
4.78 PILLAR HEIGHT

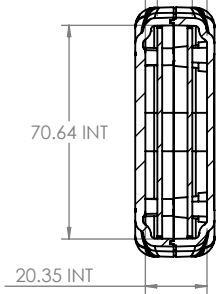

SECTION B-B

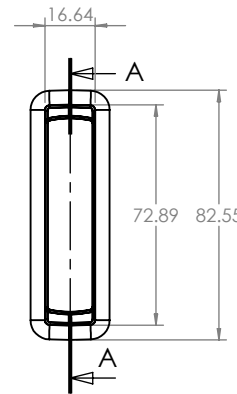
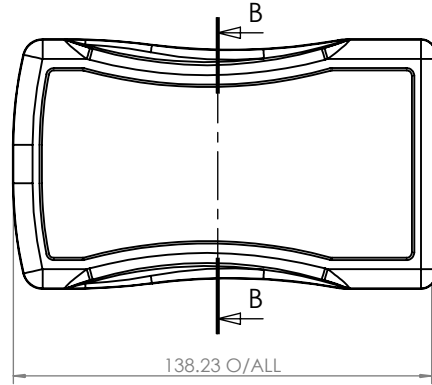

SECTION A-A

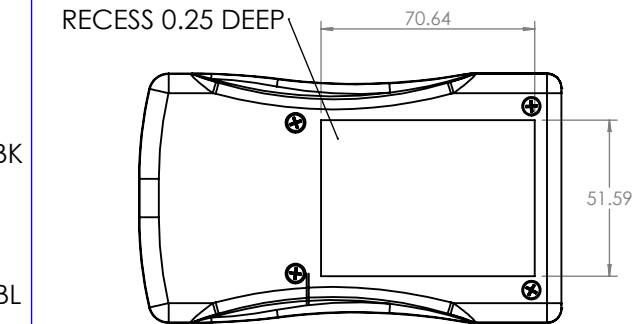
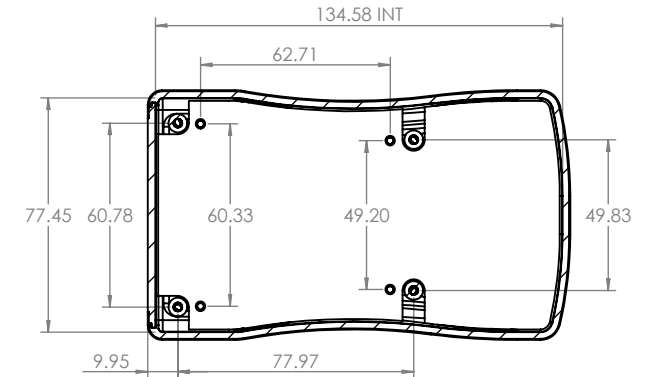

**RUBBER BOOT (OPTIONAL)**

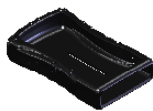

CHH452BBK

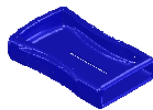

CHH452BBL

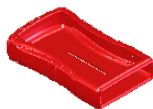

CHH452BRD

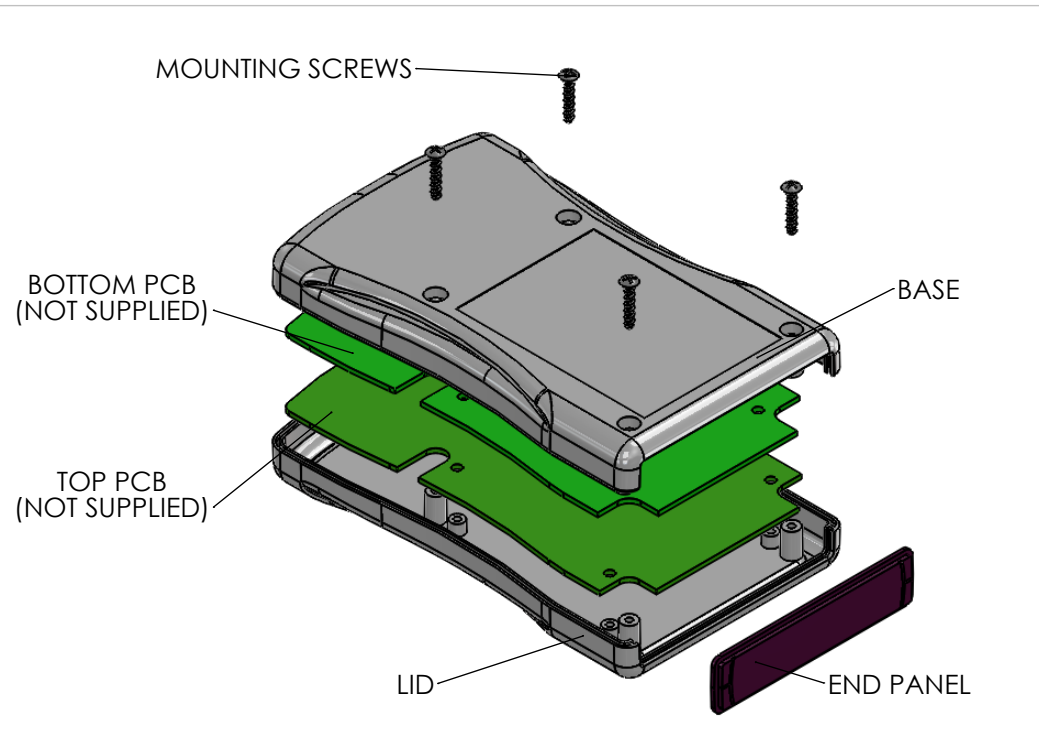

**CAMDENBOSS**

JAMES CARTER RD, MILDENHALL, SUFFOLK. IP28 7DE  
TEL: 01638 716101 FAX: 01638 716554  
EMAIL: Sales@CamdenBoss.com  
WEB: www.CamdenBoss.com

UNLESS OTHERWISE SPECIFIED:  
DIMENSIONS ARE IN MILLIMETERS

DO NOT SCALE DRAWING

REVISION. 0

GENERAL TOLERANCES +/- 0.2

TITLE: **GENERAL ASSEMBLY DRAWING  
FOR 45 SERIES PALM CASES**

FINISH:  
**FINE TEXTURE**

DWG NO.

**CHH452NBK**

A4

	NAME	SIGNED	DATE
DRAWN	JAMIE JACOBS	JNJ	15/11/12
CHK'D	-	-	-

MATERIAL:  
**UL94-5VA ABS BLACK**

PROJECTION.

SCALE: 2: 5

SHEET 1 OF 1