

**SECTION A-A  
SIDE VIEW**

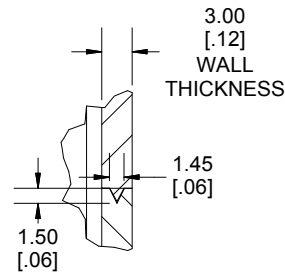

**DETAIL C  
GROOVE**

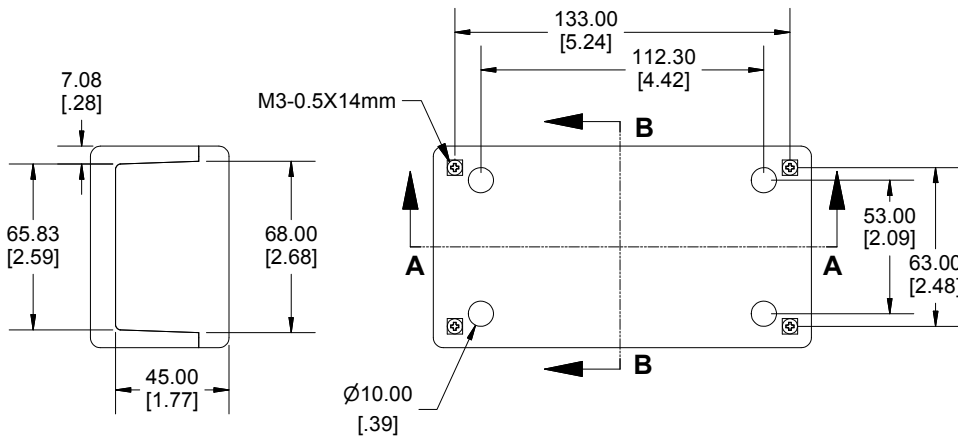
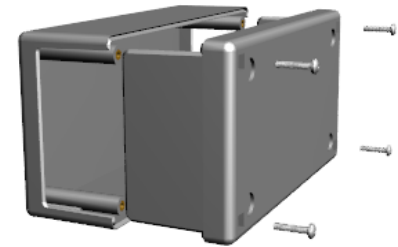

**SECTION B-B  
END VIEW**

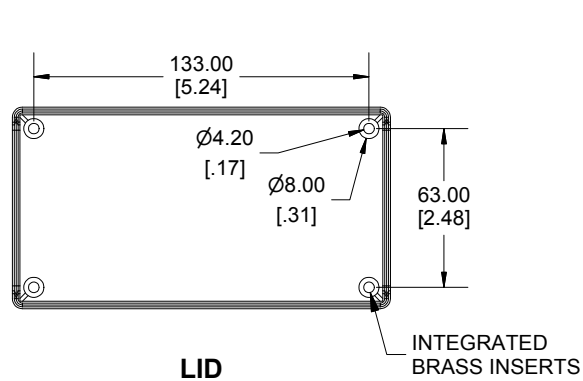
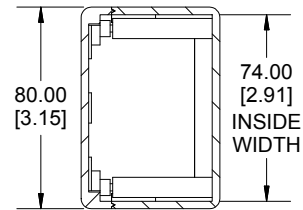

**LID**

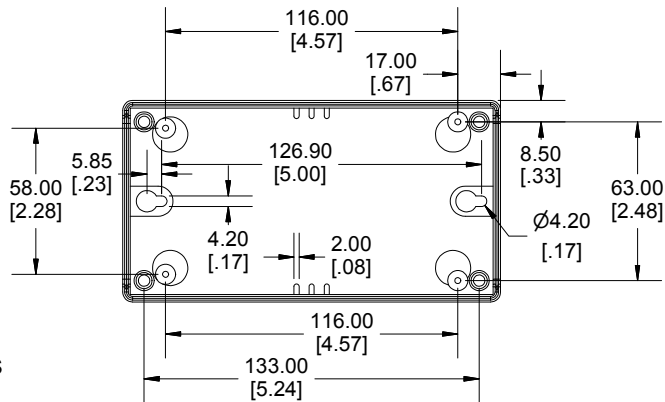

**BOX**

Enclosures can be Factory Modified ( Milling, Drilling, Printing etc.)  
Contact Factory [mjm@hammondmfg.com](mailto:mjm@hammondmfg.com) for quotes  
Solid models of this enclosure available in STEP or IGES.

<b>NOTE</b>
Purchased assembly includes box, lid, 4 cover screws, and 4 P.C. board screws.
<b>Recommended Cover Screw Torque -- 2.5 lbf-in (30 cN-m)</b>

<b>MB1580</b>	
<b>MB1580 Regular Enclosure</b>	
Lid smooth light gray (RAL 7035)	MB158055
Bottom smooth dark gray (RAL 7012)	

**HAMMOND  
MANUFACTURING™**

**MB158055**

[www.hammondmfg.com](http://www.hammondmfg.com)

Dimensions:  
mm  
[inches]