

**DETAIL D**

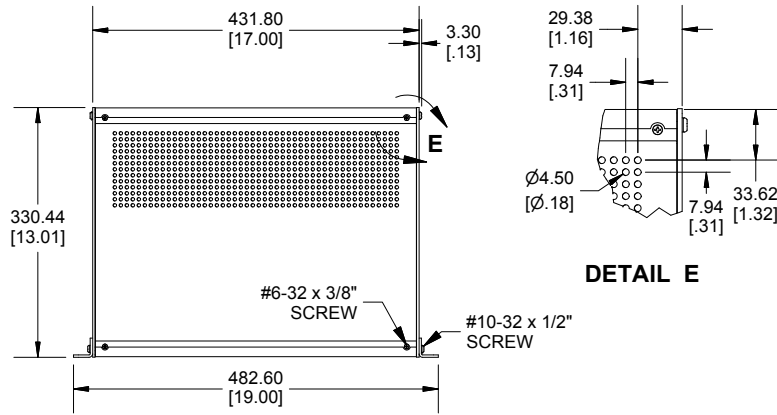

**TOP VIEW**

**DETAIL E**

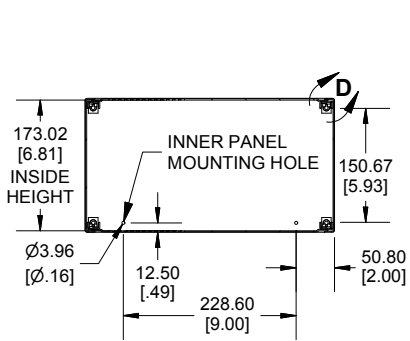
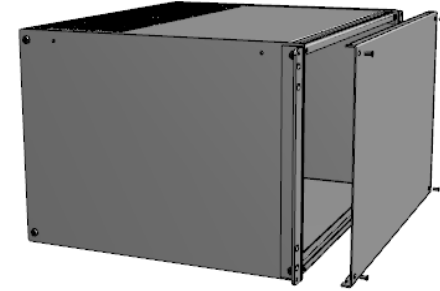

**SECTION C-C  
INSIDE SIDE VIEW**

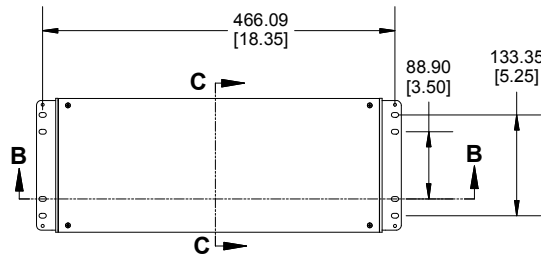

**FRONT VIEW**

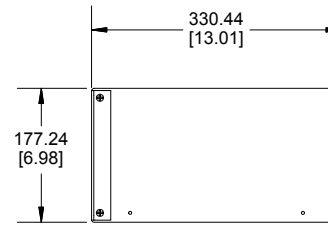

**SIDE VIEW**

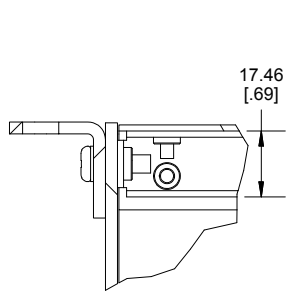

**DETAIL A**

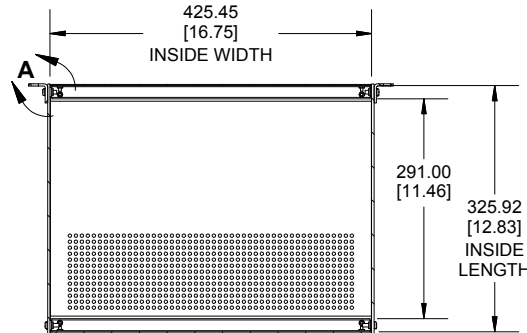

**SECTION B-B  
INSIDE BOTTOM VIEW**

Enclosures can be Factory Modified ( Milling, Drilling, Printing etc.)  
 Contact Factory [mjm@hammondmfg.com](mailto:mjm@hammondmfg.com) for quotes  
 Solid models of this enclosure available in STEP or IGES.  
 (Part number and text placement/orientation on our products are subject to change,  
 we do not recommend using them as a locating reference for modification purposes)

**NOTE**

Purchased assembly includes; 2 front/rear panels, 2 top/bottom panels, 2 side panels, 2 mounting tabs, 4 inner brackets, 24 screws and 4 rubber feet.  
 Product is not assembled for shipping purposes.

**Recommended Cover screw torque -- 8.9-9.4 lbf-in (100-110 cN-m)**

<b>RMCV</b>	
<b>RMCV190713 Regular Enclosure</b>	
Economy Rack Chassis Black	RMCS190713BK1
Economy Rack Vented Chassis Black	RMCV190713BK1
<b>ACCESSORIES</b>	
Inner Panel	RMP1913
Front & Rear Panel	RMCP7 (Textured Black)
	RMCP7BK (Smooth Black)
	RMCP7CG (Beige)
Inner Panel screws Black (#6-32 1/2) (60 pkg)	SC536BK-50
Replacement Hardware Kit: #10-32 X 5/8" Pan head black, qty 8 #6-32 X 3/8" Flat head black, qty 16 20.5 X 20.5 X 7.6 Rubber Bump, qty 4	RMCHDWKIT

**Dimensions:**  
mm  
[inches]

**HAMMOND  
MANUFACTURING**

**RMCV190713**

[www.hammondmfg.com](http://www.hammondmfg.com)